

CUSTOMER PART No.

CUSTOMER

CAN ART STD.

DIE No.

EH05447

DESCRIPTION

3" O.D. x .125" THK. TUBE

PROPOSAL No.

H-3779

NOTE: BREAK ALL CORNERS WITH 0.015" (.38 MM) RADIUS UNLESS OTHERWISE NOTED. STANDARD TOLERANCES TO APPLY UNLESS OTHERWISE SPECIFIED.

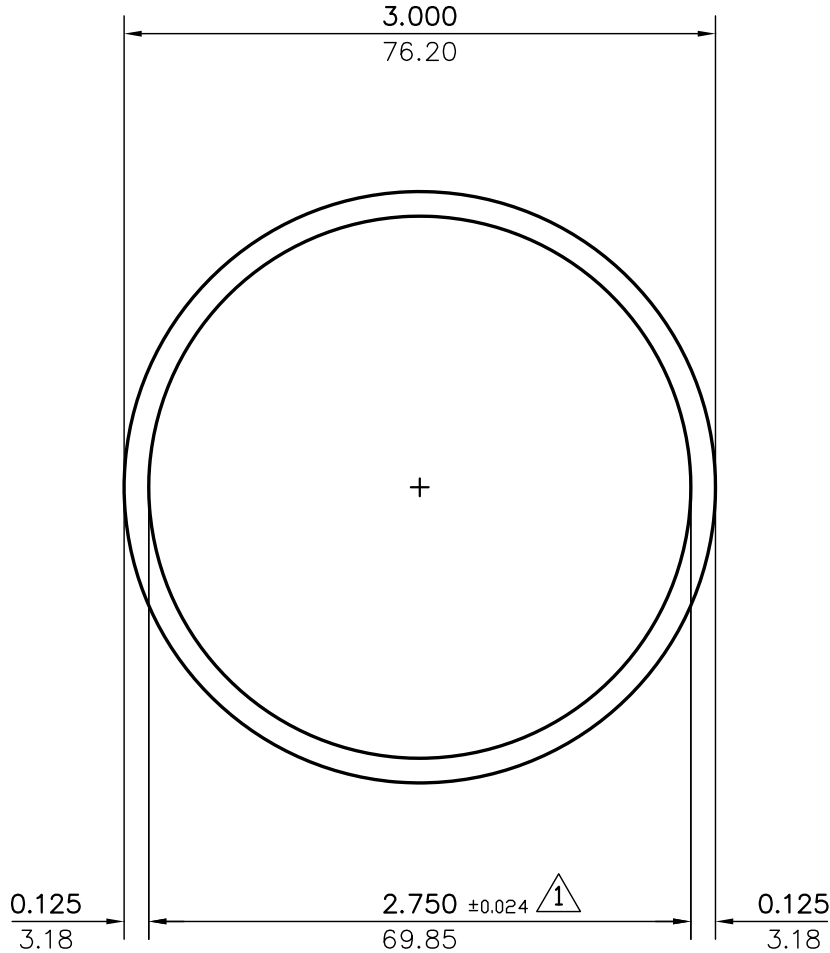

WALL THICKNESS **0.125 (3.18)** EXCEPT AS SHOWN

DATE	REV	DESCRIPTION	BY		
03/10/23	2	REMOVED ALLOY	JASON		
07/15/99	1	ADDED TOLERANCE	P.M.		
EST.AREA	1.129	IN. ²	EST.AREA	728	MM. ²
EST.WT.	1.332	LBS/FT.	EST.WT.	1.983	KG/M.
EST.PER.	18.064	IN.	EST.PER.	458.8	MM.
OUT PER.	9.425	IN.	OUT PER.	239.4	MM.
C.C.D.	3.000	IN.	C.C.D.	76	MM.
FACTOR	14	FINISH	M/F	ALLOY & TEMP.	
CKD BY		SCALE	1:1	DWN BY	C.P.
				DATE	05/18/94

CAN ART

ALUMINUM EXTRUSION INC.

85 PARKSHORE DRIVE
BRAMPTON, ONT L6T 5M1
TEL. NO. (905) 791-1464
FAX NO. (905) 791-9151
E-MAIL: canart@canart.com

THIS DRAWING IS NOT NECESSARILY A COPY OF YOUR ORIGINAL. PLEASE APPROVE DIMENSIONS AND TOLERANCES INDICATED. CAN ART ASSUMES NO RESPONSIBILITY EITHER TECHNICAL OR LEGAL FOR HAVING THIS SHAPE MADE. THE CUSTOMER AGREES TO FULLY PROTECT CAN ART ALUMINUM FROM CLAIMS OF OTHERS RESULTING FROM THIS SHAPE.

SIGNED: _____ DATE: _____